

MRL LK01

Fast Lockout relay



I: Introduction:

I-1: Applications

MRL LK01 lock out relay is used in close blocking applications for high voltage and medium voltage circuit breakers. This system contains 6 changeover heavy duty contacts.

I-2: Construction

- Withdraw able case
- Front LED indicator (locking indicator)
- Front safety LED indicator
- Latching LED facility
- Manual resetting & remote resetting
- Keeping status after power interruption

T: Technical data

T-1: Inputs

- One digital input for locking signal
 - Vin trip range: 80- 180 V dc
 - Normal Voltage: 110 V dc

T-2: Contacts Specifications

- 6 changeover heavy duty contacts:
 - Operating time: Pick up: < 15 m Sec
Drop out: < 4 m Sec
 - Contact material: AgCdO
 - Contact gap: 3 mm
 - Permanent current: 16A
 - Max peak current: 30 A for 1 Sec

 - Breaking current capacity: At 125 V dc: 0.6 A
At 110 V dc: 0.8 A

 - Max. switching voltage: 250 Vdc, 400 Vac
- One change over contact **only** for watch dog
 - Breaking current capacity: At 125Vdc: 0.4A
At 110Vdc: 0.5A
 - Contact material: AgNi0.15

Contact specification curves

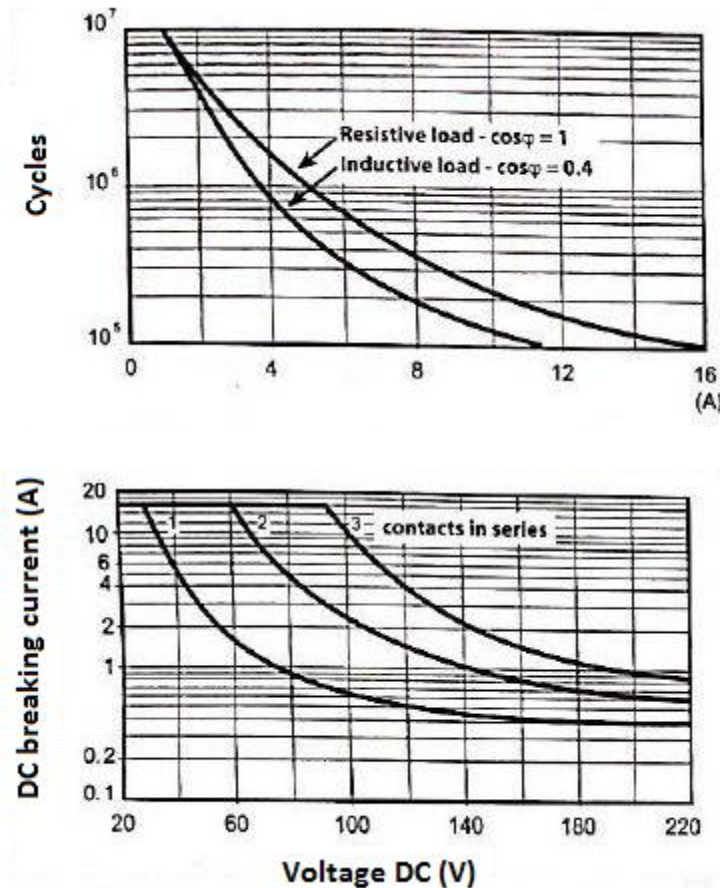

Other specifications:

- Mechanical life: 10^7 operations
- Operating temperature: $-20\text{ }^{\circ}\text{C}$ to $70\text{ }^{\circ}\text{C}$
- Storage temperature: $-20\text{ }^{\circ}\text{C}$ to $70\text{ }^{\circ}\text{C}$
- Max operating humidity: 90% at max $40\text{ }^{\circ}\text{C}$
- Insulation between input and output contacts: 6 KV
- Dielectric strength between open contacts: 1.5 KV
- Ambient altitude: $< 2000\text{ m}$

T-3: Features

- Easy to install, withdraw able structure
- High insulation
- Operating DC input range:

Aux: 60 – 180 V dc

Aux: 110 V dc

T-4: Power consumption

Locked: 0.3 W

Unlock: 2.9 W

T-5: Technical specifications according to standard

T – 5.1 Mechanical specifications

Design

Modular FMA Full draw-out Case – 2U

Mounting

Rack or flush mounting

Connections

Rear (double fasten + M4 screw per connection)

T – 5.2 Environmental conditions

Ambient Temperature Range

Per IEC 60255-6: 1988

Operating temperature range:

Continuous Withstand: –20 to +70°C

Storage Temperature Range: –20 to +70°C

Tested as per IEC 60068-2-1:2007:

–20°C storage (16 hours) –20°C operation (16 hours)

IEC 60068-2-2-2007:

+70°C storage (16 hours) +70°C operation (16 hours)

Ambient Humidity Range

Humidity:

Per IEC 60068-2-78: 2001:

Per IEC 60068-2-30: 2005:

Solar radiation

No limitation

Insulation

Rated insulation: 300

PER IEC 60255-5: 2000, Insulation resistance > 100MΩ at 500Vdc

High Voltage (Dielectric) Withstand

Per IEC 60255-5: 2000, 2Kv rms AC, 1 minute:

Between all case terminals connected together, and the case earth, and between all terminals of independent circuits.

2.0kVrms for one minute between all terminals and case earth

2.0kVrms for one minute between all terminals of independent circuits, including contact circuits

1.5kVrms for one minute across dedicated normally open contacts of output relays.

1.5kVrms AC for one minute, across open contacts and across open contacts of changeover output relays.

Impulse Voltage Withstand Test

Per IEC 60255-5: 2000

The product will withstand without damage impulses of 1.2 / 50 μ s, peak value: 5 kV, 0.5J across:

Each independent circuit and the case with the terminals of each independent circuit connected together.

Independent circuits with the terminals of each independent circuit connected together.

Terminals of the same circuit except normally open metallic contacts.

Electro Magnetic Compatibility (EMC)**DC Supply Interruption**

Per IEC60255-11:1979:

The product will withstand a 20ms interruption in the auxiliary voltage in its quiescent condition

AC Ripple on DC Supply

Per IEC60255-11:1979:

The product will operate with 12% AC ripple on the DC auxiliary supply without any additional measurement errors

Disturbances on AC Supply

Per IEC61000-4-11:1994:

The products satisfies the requirements of EN61000 - 4 - 11 for voltage dips and short interruptions.

1 MHz Burst High Frequency Disturbance Test

Per IEC 60255-22-1: 2008, Class III,

Common-mode test voltage: 2.5 kV,

Differential test voltage: 1.0 kV,

Test duration: 2 s, Source impedance: 200 Ω

Electrical Fast Transient or Burst Requirements

Per IEC 60255-22-4: 2002

The product complies with all classes up to and including Class A 4kV without any mal-operations or additional measurement errors.

Fast transient disturbances on terminal block, communications (common mode only)	2kV, 5ns rise time, 50ns decay time, 5kHz repetition time, 15ms burst, repeated every 300ms for 1min in each polarity, with a 50Ω source impedance.
Fast transient disturbances on power supply, I/O signal, data and control lines (common mode only)	4kV, 5ns rise time, 50ns decay time, 2.5kHz repetition time, 15ms burst, repeated every 300ms for 1min in each polarity, with a 50Ω source impedance.

Per IEC 61000-4-4: 2004.

The product complies with all classes up to and including Level 4 4kV without any mal-operations or additional measurement errors:

Fast transient disturbances on power supply (common mode only)	2kV, 5ns rise time, 50ns decay time, 5kHz repetition time, 15ms burst, repeated every 300ms for 1min in each polarity, with a 50Ω source impedance.
Fast transient disturbances on I/O signal, data and control lines (common mode only)	2kV, 5ns rise time, 50ns decay time, 5kHz repetition time, 15ms burst, repeated every 300ms for 1min in each polarity, with a 50Ω source impedance.

Immunity to Electrostatic Discharge

Per IEC 60255-22-2: 1997 & IEC61000-4-2:2001

The product will withstand application of all discharge levels up to the following without Mal - operation:

15 kV discharge in air to user interface, display, and exposed metalwork.

8 kV discharge in air to all communication ports.

8 kV point contact discharge to any part of the front of the product.

Conducted Emissions

Per EN 55022: 1998:

0.15 – 0.5MHz, 79dBμV (quasi peak) 66dBμV (average)

0.5 – 30MHz, 73dBμV (quasi peak) 60dBμV (average).

Radiated Emissions

Per EN 55022: 1998:

30 - 230MHz, 40dB μ V/m at 10m measurement distance

230 – 1GHz, 47dB μ V/m at 10m measurement distance.

Immunity to Radiated Electromagnetic Energy

Per IEC 60255-22-3: 2000, Class III & IEC61000-4-3:2002

Test field strength, frequency band 80 to 1000 MHz:

10 V/m, test using AM: 1 kHz / 80%, at 80 to 1GHz,

30 V/m, test using AM: 1 kHz / 80%, at 80 to 900MHz and 1.4GHz to 2.0GHz

Conducted Immunity

Per IEC 60255-22-6: 2001

10 V/m, test using AM: 1 kHz / 80%, at 0.15 to 80MHz,

Surge Immunity

Per IEC 60255-22-5: 2002

Class IV: 4kV common mode 12 Ω source impedance, 2kV differential mode 2 Ω source impedance – power supply

Class IV: 4kV common mode 42 Ω source impedance, 2kV differential mode 42 Ω source impedance – opto inputs, relays, CT, VT

Class IV - 4kV common mode 2 Ω source impedance applied to cable screen – terminal block communications

Power Frequency Magnetic Field Immunity

Per IEC 61000-4-8:2001, class V: 100A/m quiescent condition, 1000A/m short duration (1-3s)

Pulse Magnetic Field Immunity

Per IEC 61000-4-9:2001, class V: 1000A/m pulse (5 positive, 5 negative)

Damped Oscillatory Magnetic Field

Per IEC 61000-4-10:2001, class V: 100A/m @100kHz / 1MHz 2 second burst duration

Oscillatory Waves Immunity

Per IEC 61000-4-12:2001:

2.5kV peak between independent circuits and case earth

1.0kV peak across terminals of the same circuit

T-6: Connection diagram

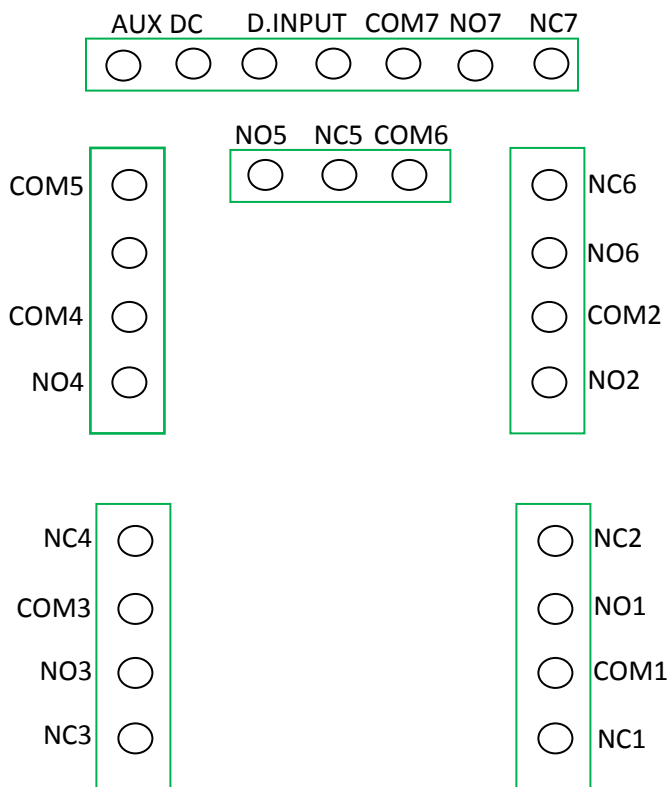

T – 7: Dimensions & panel cut out

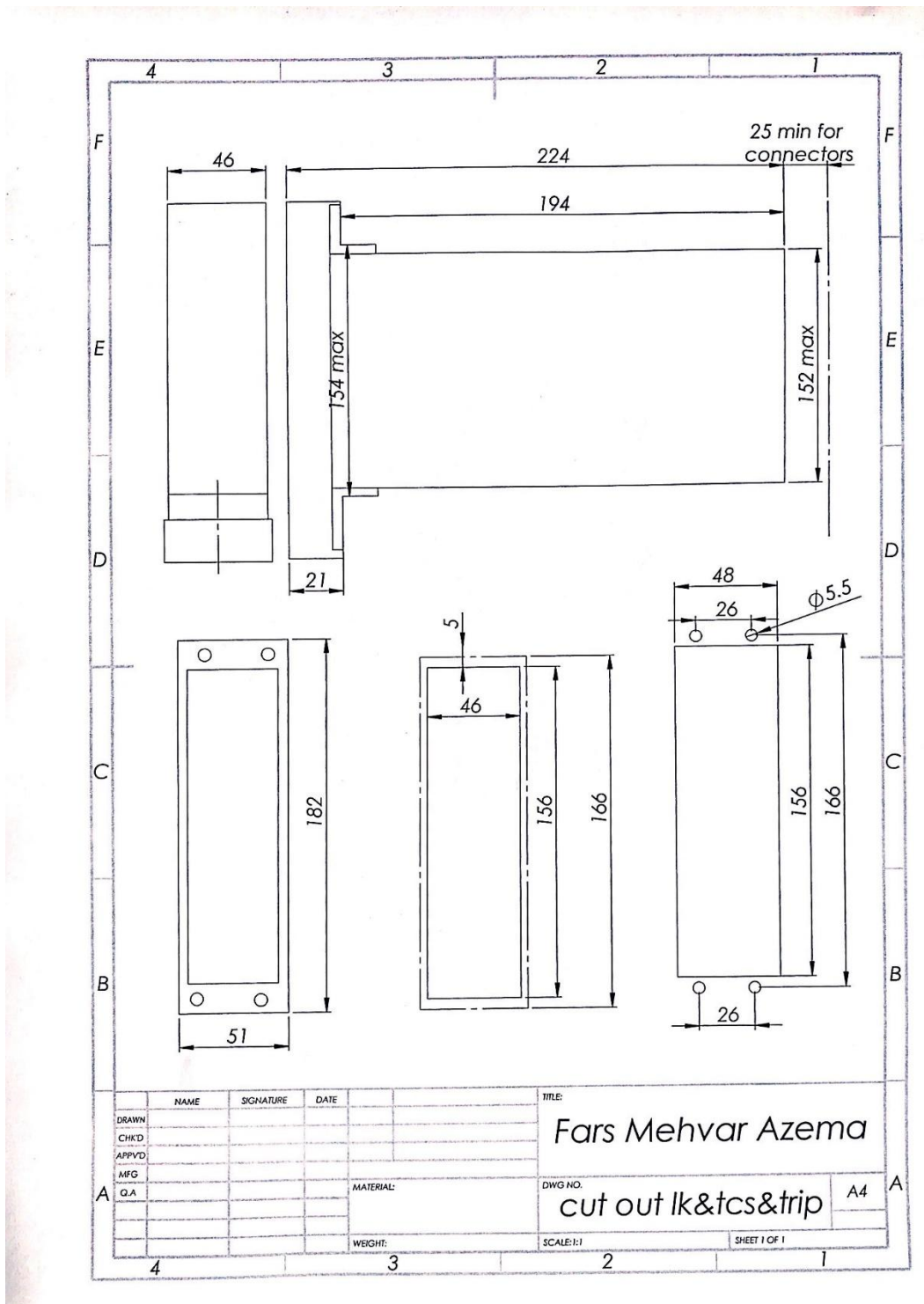

T-8: Usage guide

MRL LK01 contains 6 changeover heavy duty contacts. The following figure shows the internal block diagram and arrangement of system input and output contacts. In addition to 6 output contacts, *there is a watch dog relay and a green blinking healthy LED that always ensures the correct operation of system.*

Two other LEDs show the status of lock out relay. When a trip signal comes, the red LED turns ON, to show lock out status, and remains ON, until reset key pushed or remote reset is done. When the relay is not locked out, the blue LED is ON.

An important facility in this relay is that, keeps the contact and LED status after power interruption. This means if the relay is locked out, and DC power of relay is removed, after DC power is established again, the relay remains locked out until reset.

Note: Watch dog relay contact is not so strong as other contacts, and should be used only for watch dog alarm.

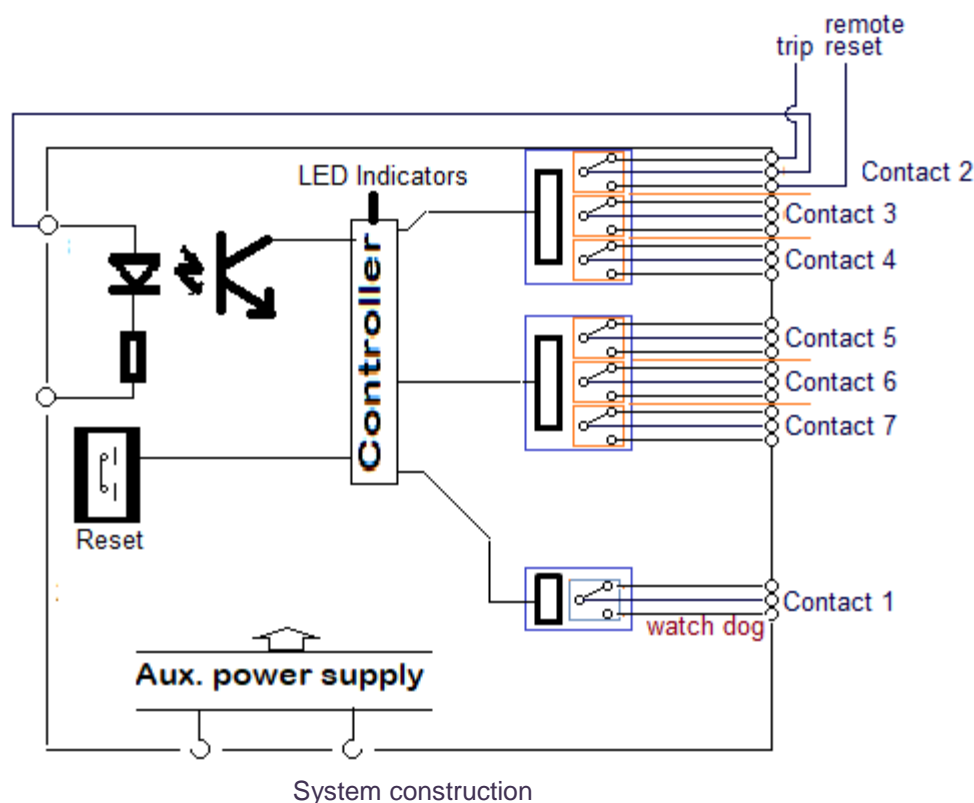

The following figure shows a typical connection diagram. The application of digital input in this relay at normal situation is to receive order to lock out, and at lock out situation is for remote reset. The order of lock out should connect to input, via the normally close of one of output contacts, and normally open of this contact connected to remote reset key, as shown in the figure.

The red LED shows the lock out status, and blue LED shows the unlock status.

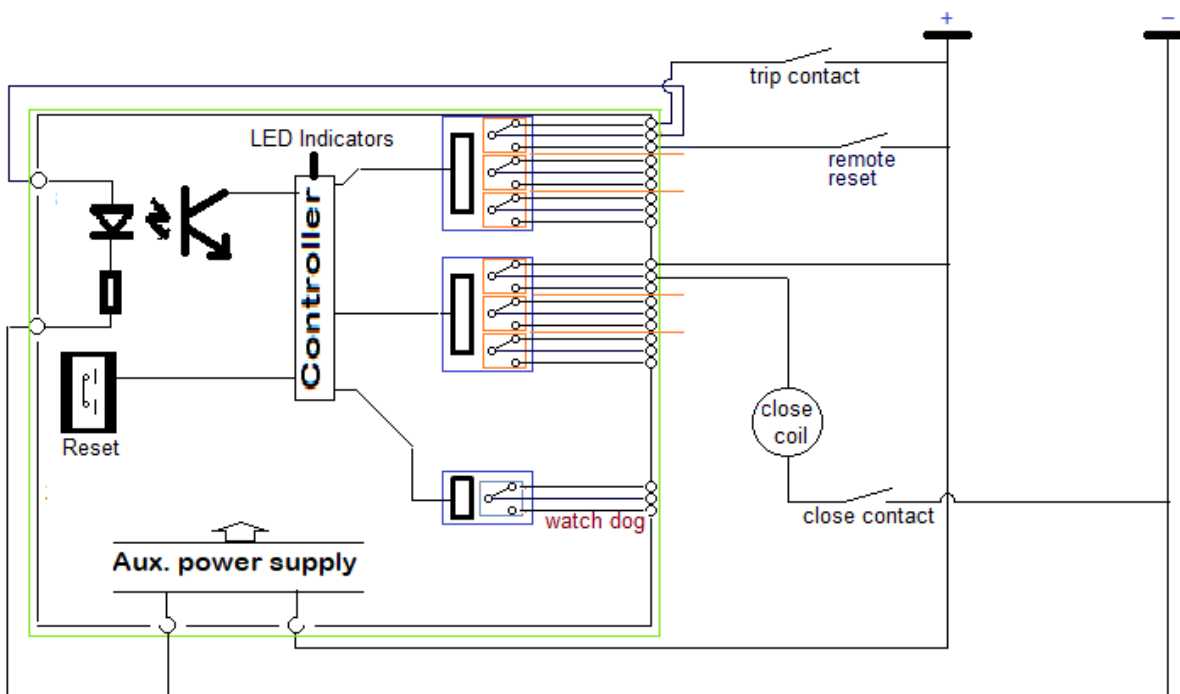

Typical connection diagram